

High-pressure submersible pumps with 4" and 5" diameter for clear water

H 802 – H 818

Application

HOMA high-pressure submersible pumps are suitable for pumping clear water with high pressure, even from boreholes or narrow wells. They are used for domestic water supply, irrigation, garden watering from cisterns or similar, in fountain displays, watering place, heat pumps, ground water drainage and so on.

In combination with the electronic control panel HPS 2 or with a pressure tank, pressure switch and an electrical control panel the pumps can operate automatically (see accessories).

Installation: The pumps operate in vertical or horizontal position. For vertical operation in a well the pump must be suspended on a rope.

Pumped liquid: Clear water.

Max. temperature of the liquid: 35°C.

Operation: permanent (S1)

Design

Fully submersible drainage pump consisting of:

Pump: Multistage centrifugal pump with vertical discharge.

Impeller: Closed multi-channel impellers, spherical clearance 1,5 mm. Wear rings made of stainless steel.

Motor: Fully submersible, pressure tight electric motor, oil-filled. Insulation class F. Motor protection IP 68. Thermal sensors imbedded in the motor winding.

Shaft/bearings: Large diameter stainless steel rotor shaft, pre-lubricated bearings.

Seals: Double shaft seal with mechanical seal and additional shaft seal ring.

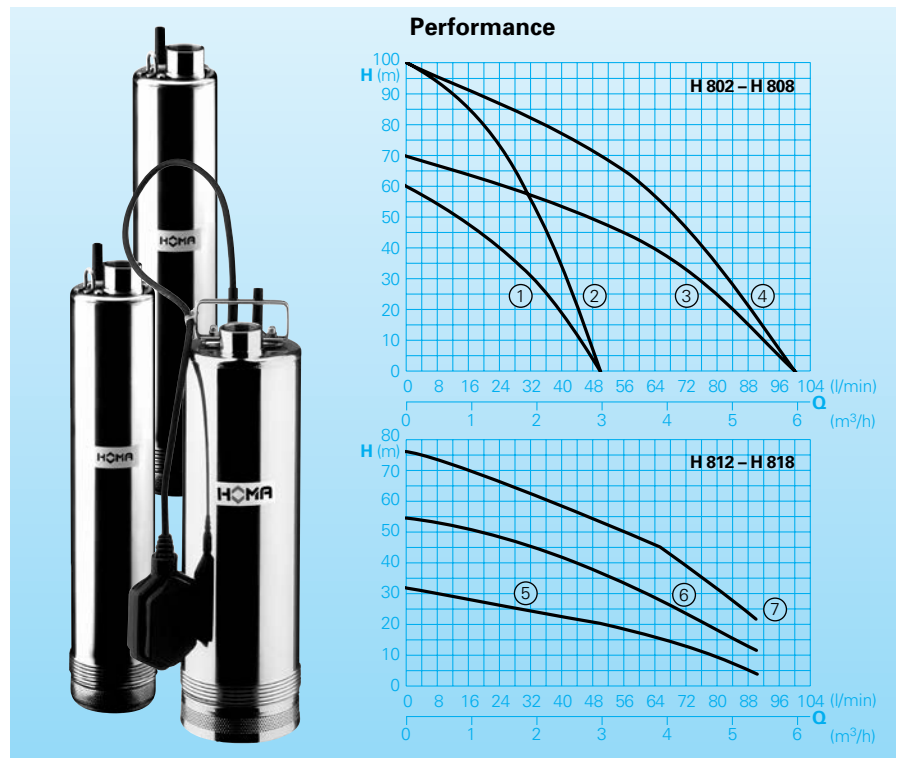

Technical Data

Curve No.	Pump type	Motor-input P1 (kW)	Motor-output P2 (kW)	Nominal current (A)	Weight (kg)	Cable type
①	H 802 W	0,85	0,5	5,0	12	H07RN-F4G1
②	H 804 W	1,1	0,75	6,0	13	H07RN-F4G1
③	H 806 W	1,1	0,75	6,0	13	H07RN-F4G1
④	H 808 W	1,6	1,1	8,0	15	H07RN-F4G1
⑤	H 812 WA	1,0	0,6	4,0	12	H07RN-F3G1
⑥	H 816 WA	1,4	0,9	6,0	13	H07RN-F4G1
⑦	H 818 WA	1,8	1,2	8,0	15	H07RN-F3G1

Voltage: 230-240 V / 1 Ph

Speed: 2900 rpm

Model WA: With automatic level control HOMA-Nivomatik.

Materials:

Pump housing, motor housing, rotor shaft, Suction sieve	Stainless steel
Impeller	Glass-fibre reinforced synthetic material (composite)
Mechanical seal	Carbone graphite/ aluminium
Elastomere	Perbonane

Equipment supplied

H804, H806, H808:
Pump with 20 m of cable, control box with capacitor, overload protection and plug.
H802, H812, H816, H818:
Pump with 20 m of cable and plug.

Dimensions

H 802 – H 808 W

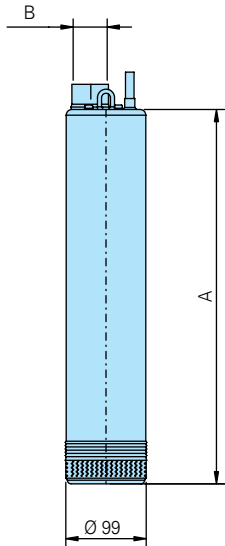

H 812 WA – H 818 WA

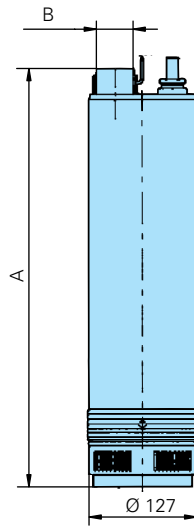

Pump type	A	B
H 802 W	470	BSP 1" F
H 804 W	600	BSP 1 1/4" F
H 806 W	520	BSP 1 1/4" F
H 808 W	630	BSP 1 1/4" F

Pump type	A	B
H 812 WA	470	BSP 1 1/4" F
H 816 WA	540	BSP 1 1/4" F
H 818 WA	620	BSP 1 1/4" F

all dimensions in mm

Accessories

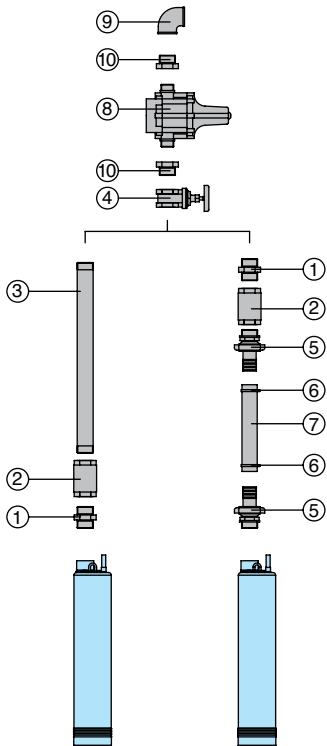

Part Description	Dimension	Part. No.
① Galvanized double nipple	BSP 1 1/4" M	2009011
② Brass non-return valve	BSP 1 1/4" F	2009027
③ Thread pipe	BSP 1 1/4" F	2100153
④ Bronze gate valve	BSP 1 1/4" F	2216012
⑤ Brass STA-hose coupling	BSP 1 1/4" M	2001413
⑥ Hose band	1 1/4"	2303252
⑦ Reinforced hose, pressure resistant up to 7 bar, per m	1 1/4" Ø	2632030

Part Description	Dimension	Part. No.
⑧ HPS 2 electronic pump control box with dry-run protection	BSP 1" M	1468560
⑨ 90° galvanized elbow	BSP 1 1/4" F/M BSP 1 1/4" F	2111405 2113604
⑩ Brass reduction piece	BSP 1 1/4" M x BSP 1" F	2109400
○ Diaphragm pressure tank with pressure switch and control box dry-run protection		On request

HOMA
P U M P T E C H N O L O G Y

HOMA Pumpenfabrik GmbH
P.O.Box 22 63, D-53814 Neunk.-Seelscheid
Tel. +49 (0) 22 47/702-0, Fax +49 (0) 22 47/702-44
e-mail: info@homa-pumpen.de
www.homapumps.com

Deepwell submersible pumps with 3" diameter for clear water

H 832

Application

HOMA high pressure submersible pumps are suitable for pumping clear water with high pressure from bore holes or narrow wells. They are used for domestic water supply, irrigation, garden watering from cisterns or similar, in fountain displays, watering place, ground water drainage etc.

In combination with the electronic control panel HPS 2 or with a pressure tank, pressure switch and an electrical control panel the pumps can operate automatically (see accessories).

Installation: The pumps operate in vertical or horizontal position. For vertical operation in a well the pump must be suspended on a rope.

Pumped liquid: Clear water.

Max. liquid temperature: 35°C.

Operation: Permanent (S1).

Design

Fully submersible pump consisting of:

Pump: Multistage centrifugal pump with vertical discharge BSP 1" F.

Impeller: Closed multi-channel impellers, spherical clearance 1,5 mm. Wear rings made of stainless steel.

Motor: Fully submersible, pressure tight electric motor, oil filled. Insulation class F. Motor protection IP 68. Thermal sensors embedded in the motor winding.

Shaft/bearings: Large diameter stainless steel rotor shaft, pre-lubricated bearings.

Seals: Mechanical seal.

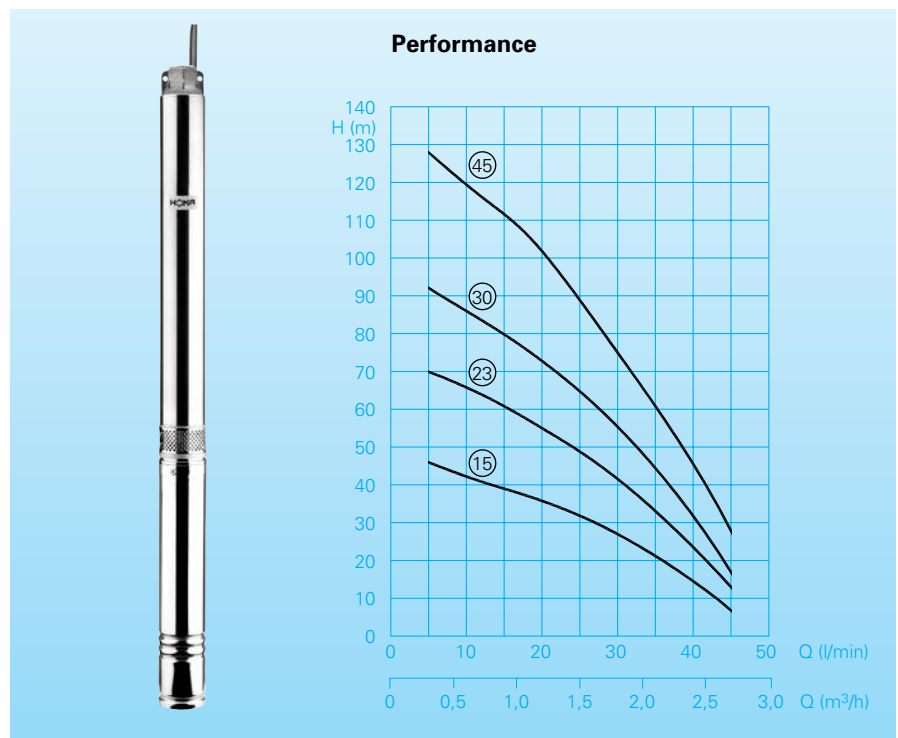

Technical Data

Curve No.	Pump type	Motor-output P ₂ (kW)	Capacitor* (µF)	Nominal current (A)	Cable length (m)	Weight (kg)
15	H 832-15/0,37 W	0,37	16	3,75	1,5	9,3
15	H 832-15/0,37 D	0,37		2,00	1,5	9,3
23	H 832-23/0,55 W	0,55	20	4,50	1,5	10,8
23	H 832-23/0,55 D	0,55		2,10	1,5	10,5
30	H 832-30/0,75 W	0,75	25	5,85	1,5	12,4
30	H 832-30/0,75 D	0,75		2,50	1,5	12,0
45	H 832-45/1,10 D	1,10		3,20	1,5	14,4

Speed: 2900 rpm

*Capacitor: For the operation it is necessary to install a capacitor in the control box.

Model W: 230-240V/1Ph

Model D: 400-415V/3Ph

Materials:

Pump housing	Stainless steel
Motor housing,	Stainless steel
Suction sieve,	
Motor shaft	
Impeller	Glass-fibre reinforced synthetic material (composite)
Mechanical seal	Carbone graphite / Stainless steel
Elastomere	Perbonane

Equipment supplied

Pump with integrated non-return valve and 1,5 m of cable. The single phase pumps require a capacitor for operation, which is integrated in the control box (see accessories).

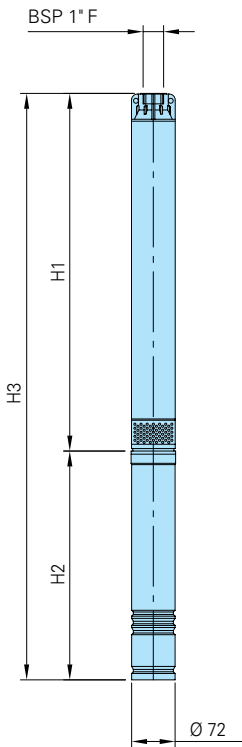

Domestic water supply system with electronic control box HPS 2

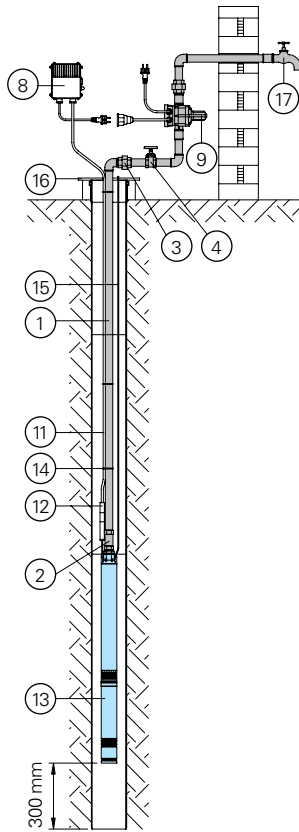

Domestic water supply system with diaphragm pressure tank

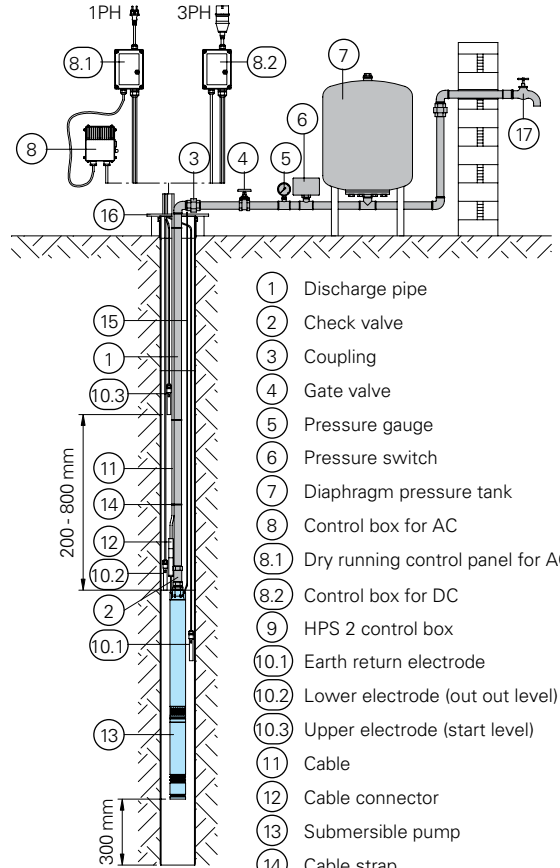

- ① Discharge pipe
- ② Check valve
- ③ Coupling
- ④ Gate valve
- ⑤ Pressure gauge
- ⑥ Pressure switch
- ⑦ Diaphragm pressure tank
- ⑧ Control box for AC
- ⑧.1 Dry running control panel for AC
- ⑧.2 Control box for DC
- ⑨ HPS 2 control box
- ⑩.1 Earth return electrode
- ⑩.2 Lower electrode (out level)
- ⑩.3 Upper electrode (start level)
- ⑪ Cable
- ⑫ Cable connector
- ⑬ Submersible pump
- ⑭ Cable strap
- ⑮ Steel rope
- ⑯ Supporting clamp
- ⑰ Hydrants

Pump type	H1	H2	H3
H 832-15/0,37 W	580	371	951
H 832-15/0,37 D	580	371	951
H 832-23/0,55 W	780	371	1151
H 832-23/0,55 D	780	371	1151
H 832-30/0,75 W	1000	391	1391
H 832-30/0,75 D	1000	391	1391
H 832-45/1,10 D	1380	410	1790

all dimensions in mm

Part Description	Dimension	Part-No.
① Galvanized tube, per m BSP 1"		2100150
○ Galvanized fittings,		on request
○ Tube PE-HD, polyethylene		on request
○ Screw connection, PE-HD		on request
○ Reinforced hose, per m BSP 1"		2632025
○ Brass STA-hose coupling BSP 1"		2001310
○ Hose band BSP 1"		2302330
② Bronze non-return valve BSP 1" F		2211113
③ Galvanized coupling BSP 1" F		2114303
④ Bronze gate valve BSP 1" F		2216010
⑤ Manometer 0 – 10 bar BSP 1/4" M		8503240
⑥ Pressure switch 0,5 – 11 bar BSP 1/4" M		1254011
⑦ Diaphragm pressure tank		on request
⑧ Single phase control panel with motor	0,37 kW	1921000
	0,55 kW	1921002
protection, capacitor, on-off-switch- plug, up to	0,75 kW	1921003

Part Description	Dimension	Part-No.
⑧.1 Single phase protection against dry-running with composite housing IP 54, 3 electrodes, electro relays, plug, without electrode cable up to	0,55 kW	1921030
	0,75 kW	1921032
⑧.2 Three phase control panel with motor protection, on-off-switch, CEE-plug, up to	0,37 kW	1926010
	0,75 kW	1926015
	1,1 kW	1926020
⑧.2 Three phase control panel as above, additional with relay and 2 electrodes (mounting a composite tube a third electrode must be used as an earth conductor), without cable, up to	0,37 kW	1921070
	0,75 kW	1921072
	1,1 kW	1921074
⑨ HPS 2 electronic pump control box with dry-run protection	BSP 1" M	1468560
⑩ Electrode		1041207
⑪ Rubber-sheated cable, per m		1041541
⑫ Coupling sleeve		1124020



HOMA Pumpenfabrik GmbH
 P.O.Box 22 63, D-53814 Neunk.-Seelscheid
 Tel. +49 (0) 22 47/702-0, Fax +49 (0) 22 47/702-44
 e-mail: info@homa-pumpen.de
 www.homapumps.com

Deepwell Submersible Pumps

H 842 - H 863

Application

HOMA deepwell submersible pumps are suitable for pumping clear water with high pressure, even from bore holes or narrow wells. They are used for domestic water supply, irrigation, garden watering from cisterns or similiar, in fountain displays, watering place, heat pumps, ground water drainage and so on. In combination with the electronic control panel HPS 2 or with a pressure tank, pressure switch and an electrical control panel the pumps can operate automatically (see accessories).

Installation: The pumps operate in vertical or horizontal position. For vertical operation in a well the pump must be suspended on a rope.

Pumped liquid: Clear water.

Max. temperature of the medium: 35°C.

Max. sand contents: 40g/m³.

Operation: Permanent (S1).



Design

Fully submersible motor-pump unit consisting of:

Pump: Multistage centrifugal pump with flanged motor. Check valve integrated in the pump housing.

Impellers: Closed multi-channel impellers (H 846 and H 847 open mixed-flow impellers).

Motor: Pressure tight, medium cooled wet-type motor. Water tight connector. Speed 2900 rpm. Cable: 1m flat cable, 4-core.

Materials

Pump housing:	
H 842-H 847:	Stainless steel
H 862-H 863:	Cast iron
Impellers:	
H 842-H 847:	Polycarbonate
H 862-H 863:	Noryl
Diffusers:	
H 842-H 847:	Polycarbonate/ Stainless steel
H 862-H 863:	Noryl/Stainless steel
Wear rings, shaft, outer housing, cable guard, screws	Stainless steel
Shaft bearings	Sintered bronze/ stainless steel
Motor housing, shaft	Stainless steel
Bearings	Carbon graphite

Dimensions

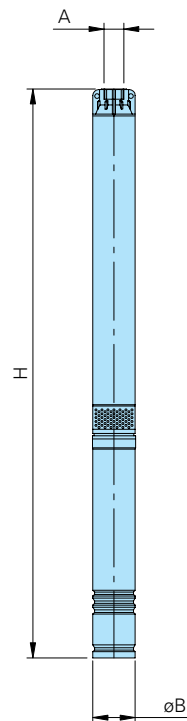

<u>A:</u>	
H 842-H 844:	1 ¼" F
H 846-H 847:	2" F
H 862-H 863:	3" F

<u>Ø B:</u>	
H 842-H 847:	96 mm
H 862-H 863:	114 mm

H:
See individual tables

Equipment supplied

Pump with free cable end. The single phase pumps require a capacitor for operation, which is integrated in the control box (see accessories).

Deepwell Submersible Pumps 4"

H 842

H 844

H 846

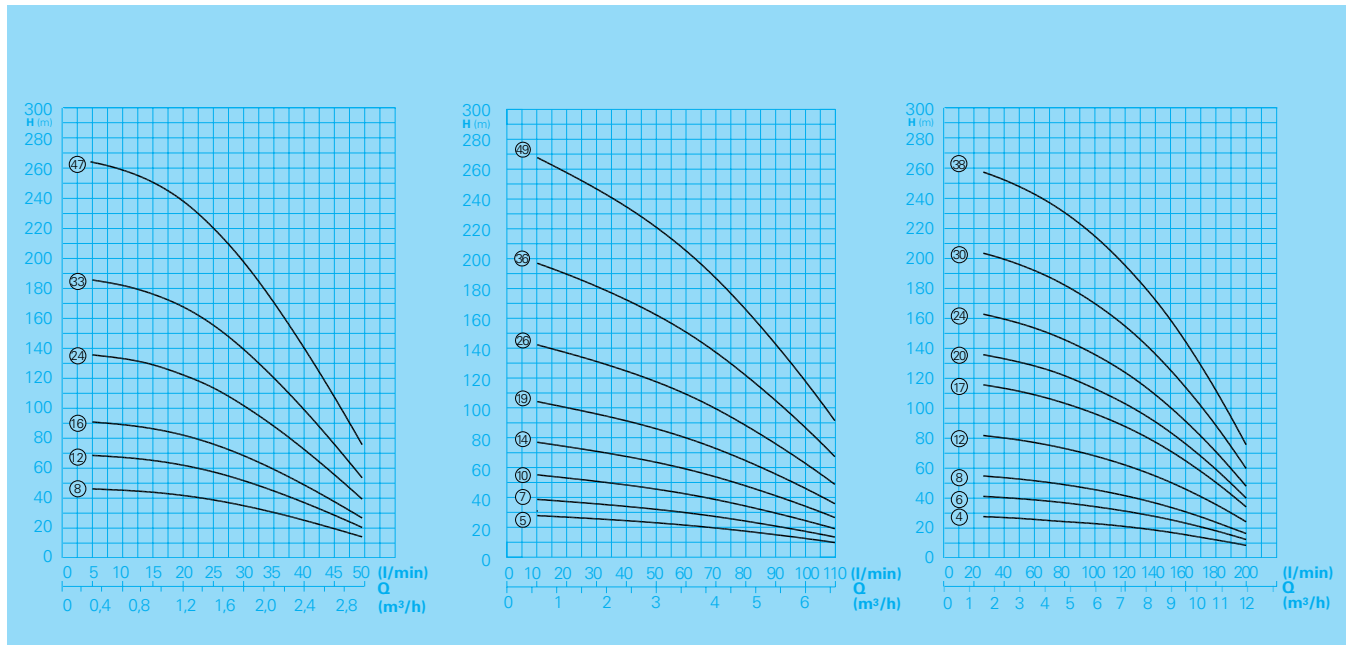

Technical Data

Single phase models

Type	Motor output P_2 (kW)	Nominal current (A)	Dim. H (mm)	max. Weight (kg)
H 842-8/0,37 W	0,37	4,0	607	10,7
H 842-12/0,55 W	0,55	6,0	726	12,5
H 842-16/0,75 W	0,75	7,3	843	14,7
H 842-24/1,1 W	1,1	8,9	1081	18,6
H 842-33/1,5 W	1,5	11,1	1314	21,0
H 842-47/2,2 W	2,2	15,9	1750	27,3

Type	Motor output P_2 (kW)	Nominal current (A)	Dim. H (mm)	max. Weight (kg)
H 844- 5/0,37 W	0,37	4,0	577	10,2
H 844- 7/0,55 W	0,55	6,0	666	11,8
H 844-10/0,75 W	0,75	7,3	783	14,0
H 844-14/1,1 W	1,1	8,9	966	17,4
H 844-19/1,5 W	1,5	11,1	1144	19,5
H 844-26/2,2 W	2,2	15,9	1430	24,3

Type	Motor output P_2 (kW)	Nominal current (A)	Dim. H (mm)	max. Weight (kg)
H 846- 4/0,75 W	0,75	7,3	708	13,5
H 846- 6/1,1 W	1,1	8,9	871	16,9
H 846- 8/1,5 W	1,5	11,1	1004	18,7
H 846-12/2,2 W	2,2	15,9	1290	23,8

Three phase models

Type	Motor output P_2 (kW)	Nominal current (A)	Dim. H (mm)	max. Weight (kg)
H 842-8/0,37 D	0,37	1,1	588	9,9
H 842-12/0,55 D	0,55	1,6	697	11,3
H 842-16/0,75 D	0,75	2,1	816	13,3
H 842-24/1,1 D	1,1	3,0	824	16,0
H 842-33/1,5 D	1,5	4,0	1257	18,6
H 842-47/2,2 D	2,2	5,9	1646	22,8

Type	Motor output P_2 (kW)	Nominal current (A)	Dim. H (mm)	max. Weight (kg)
H 844- 5/0,37 D	0,37	1,1	558	9,4
H 844- 7/0,55 D	0,55	1,6	637	10,6
H 844-10/0,75 D	0,75	2,1	756	12,6
H 844-14/1,1 D	1,1	3,0	909	14,8
H 844-19/1,5 D	1,5	4,0	1087	17,1
H 844-26/2,2 D	2,2	5,9	1326	19,8
H 844-36/3,0 D	3,0	7,8	1748	25,2
H 844-49/4,0 D	4,0	10,0	2302	35,2

Type	Motor output P_2 (kW)	Nominal current (A)	Dim. H (mm)	max. Weight (kg)
H 846- 4/0,75 D	0,75	2,1	681	12,1
H 846- 6/1,1 D	1,1	3,2	859	14,3
H 846- 8/1,5 D	1,5	4,0	947	16,3
H 846-12/2,2 D	2,2	5,9	986	19,3
H 846-17/3,0 D	3,0	7,8	1518	24,3
H 846-20/3,7 D	3,7	9,1	2008	29,5
H 846-24/4,1 D	4,1	10,0	2148	34,3
H 846-30/5,5 D	5,5	13,7	2538	42,1
H 846-38/7,5 D	7,5	18,8	3024	48,9

Deepwell Submersible Pumps 6"

H 847

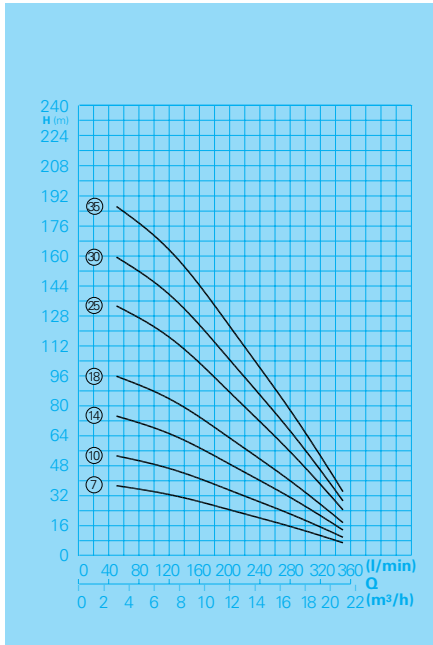

H 862

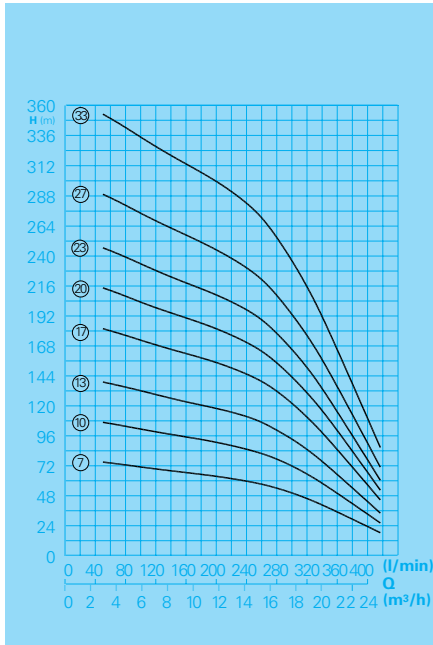

H 863

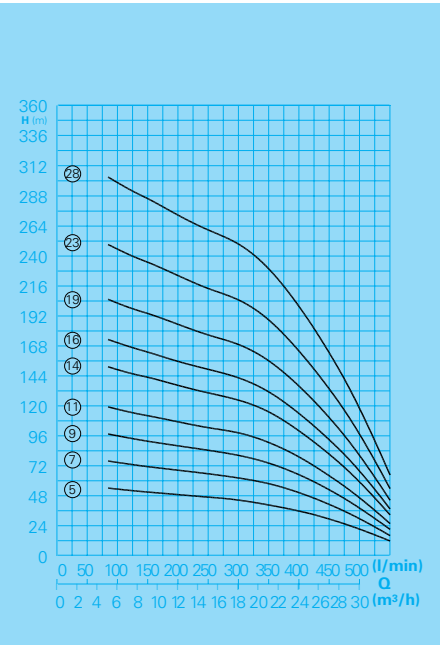

Technical Data

Single phase models

Type	Motor output P_2 (kW)	Nominal current (A)	Dim. H (mm)	max. Weight (kg)
H 847- 7/1,5 W	1,5	11,1	1144	18,7
H 847-10/2,2 W	2,2	15,9	1450	24,3

Three phase models

Type	Motor output P_2 (kW)	Nominal current (A)	Dim. H (mm)	max. Weight (kg)
H 847- 7/1,5 D	1,5	4,0	1087	16,3
H 847-10/2,2 D	2,2	5,9	1346	19,8
H 847-14/3,0 D	3,0	7,8	1798	25,2
H 847-18/4,0 D	4,0	10,0	2263	35,6
H 847-25/5,5 D	5,5	13,7	2993	45,8
H 847-30/7,5 D	7,5	18,8	3463	52,6
H 847-35/7,5 D	7,5	18,8	3849	56,1

Type	Motor output P_2 (kW)	Nominal current (A)	Dim. H (mm)	max. Weight (kg)
H 862- 7/4 D	4,0	10,0	1183	37,2
H 862-10/5,5 D	5,5	13,7	1413	44,0
H 862-13/7,5 D	7,5	18,8	1604	49,1
H 862-17/9,2 D	9,2	20,7	1664	64,6
H 862-20/11 D	11,0	23,3	1811	69,5
H 862-23/12,9 D	12,9	27,0	2061	77,3
H 862-27/15 D	15,0	31,3	2211	79,4
H 862-33/18,5 D	18,5	38,5	2506	89,4

Type	Motor output P_2 (kW)	Nominal current (A)	Dim. H (mm)	max. Weight (kg)
H 863- 5/4 D	4,0	10,0	1148	36,5
H 863- 7/5,5 D	5,5	13,7	1358	43,0
H 863- 9/7,5 D	7,5	18,8	1548	47,8
H 863-11/9,2 D	9,2	20,7	1529	62,5
H 863-14/11 D	11,0	23,3	1701	67,7
H 863-16/12,9 D	12,9	27,0	1861	74,7
H 863-19/15 D	15,0	31,3	2001	76,5
H 863-23/18,5 D	18,5	38,5	2321	85,9
H 863-28/22 D	22,0	45,3	2617	94,9

Installations

Domestic water supply with electronic pump control box HPS 2 (only for single phase submersible pumps).

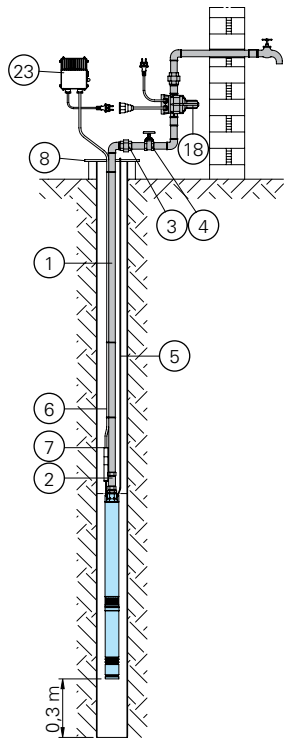

Domestic water supply with diaphragm pressure tank.

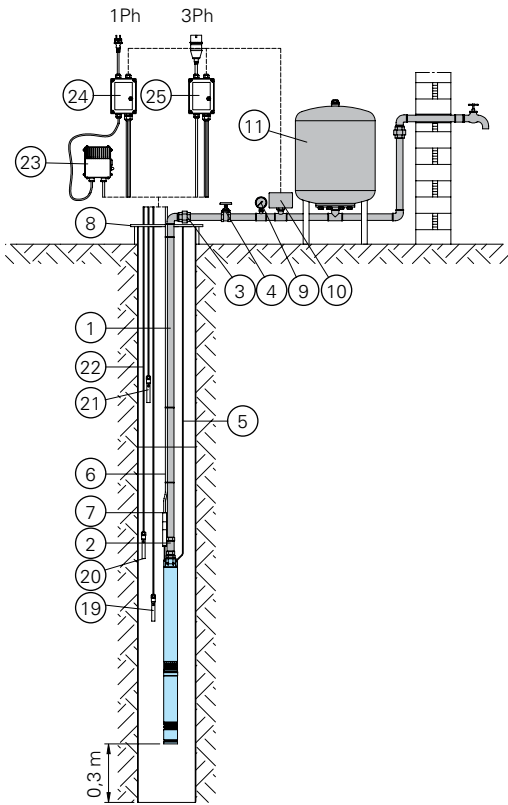

Domestic water supply with pressure tank

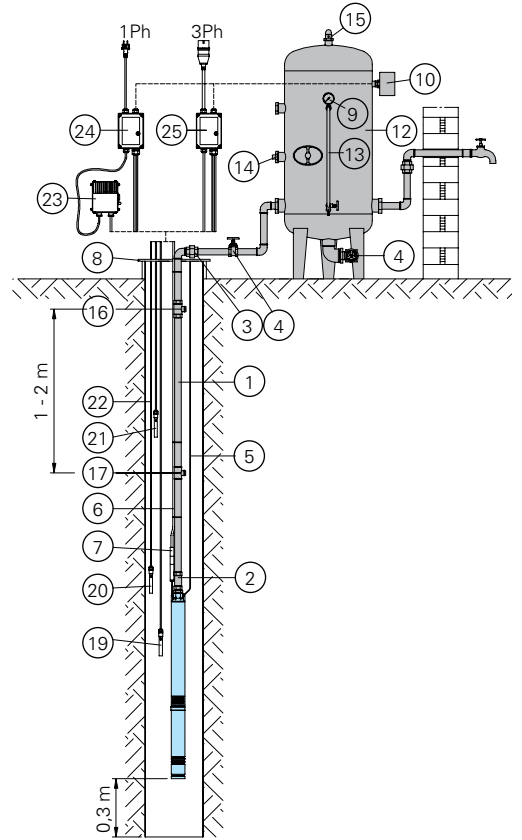

Accessories

Description	Dimensions	Part No.	Description	Dimensions	Part No.	Description	Dimensions	Part No.
① Galvanized tube, per m	BSP 1 1/4"	2100153	⑪ Diaphragm pressure tank		on request	⑳ Single phase control panel with motor	0,37 kW	1921010
	BSP 2"	2100205				protection, capacitor,	0,55 kW	1921012
	BSP 3"	2100305	⑫ Galvanized pressure tank		on request	on-off-switch, plug, up to	0,75 kW	1921014
Galvanized fittings		on request					1,1 kW	1921016
Composite tube PE-HD	BSP 1 1/4"–BSP 3"	on request	⑬ Water level set	BSP 1/2"M	8503210		1,5 kW	1921018
Composite fittings, PE-HD		on request	⑭ Mixer valve	BSP 1 1/4"M	8503230	㉔ Single phase protection against dry-running with composite housing IP54,	2,2 kW	1921020
② Bronze non-return valve	BSP 1 1/4"F	2211213	⑮ Safety valve 6 bar	BSP 1"F	8503215	2 electrodes, electro relays, plug, (mounting a composite tube a third electrode must be used as an earth conductor) without electrode cable up to	0,55 kW	1921030
	BSP 2"F	2211413	⑯ Aeration valve	1 1/4"F	2009030		2,2 kW	1921032
	BSP 3"F	2211613		2"F	2009033			
③ Galvanized coupling	BSP 1 1/4"F/M	2114304		3"F	on request			
	BSP 2"F/M	2114311	⑰ Air release valve	BSP 1/2"M	8503220	㉕ Three phase control panel with motor	1,6 A	1926010
	BSP 3"F/M	on request	⑱ HPS 2 electronic pump control box with dry-run protection, max. switching capacity BA, max. pressure 10 bar	BSP 1"M	1468560	protection, on-off-switch, CEE-plug, up to	2,5 A	1926015
④ Flanged gate valve	BSP 1 1/4"F	2216012					4,0 A	1926020
	BSP 2"F	2216020	⑲ gnd-electrode		1610992		6,3 A	1926025
	BSP 3"F	2216030	㉖ off-electrode		1610992		10,0 A	1926030
⑤ Rope, stainless steel	4,0 mm	on request	㉗ on-electrode		1610992		16,0 A	1926035
⑥ Rubber-sheated cable, per m, up to 4,0 kW	4G1,5	1041541	㉘ Electrode, per m		1041207	○ Three phase control panel as above, together with protection against dry-running with relay and 2 electrodes (mounting a composite tube a third electrode must be used as an earth conductor) without electrode cable up to	1,6 A	1921070
up to 5,5 kW	4G2,5	1041542					2,4 A	1921072
up to 9,2 kW	4G4	1041745					4,0 A	1921074
Rubber-sheated cable, different length up to 4,0 kW	4G1,5/ 10M	1041170					6,0 A	1921076
	4G1,5/ 20M	1041171					10,0 A	1921078
	4G1,5/ 25M	1041181					16,0 A	1921080
	4G1,5/ 30M	1041177						
	4G1,5/ 50M	1041130						
from 5,5 kW	4G2,5/ ...M	on request						
from 9,2 kW	4G4/ ...M	on request						
⑦ Coupling sleeve	up to 4G2,5	1124030						
	from 4G4	1124020						
⑧ Supporting clamp		on request						
⑨ Manometer 0-10 bar	BSP 1/4"M	8503240						
Manometer with higher measuring range		on request						
⑩ Pressure switch 0,5-11bar	BSP 1/4"M	1254011						
Pressure switch higher pressure range		on request						



HOMA Pumpenfabrik GmbH
P.O.Box 22 63, D-53814 Neunk.-Seelscheid
Tel. +49 (0) 22 47/702-0, Fax +49 (0) 22 47/702-44
e-mail: info@homa-pumpen.de
www.homapumps.com