



Axial-Vollkegeldüsen

Baureihe 460 / 461



Besonders gleichmäßige Vollkegelzerstäubung. Große freie Querschnitte durch optimierten Flügel-drallkörper.

Anwendung:

Reinigungs- und Waschprozesse, Kühlen von gasförmigen und festen Stoffen, Flächenbesiedlung, Mattenbesprühung in Luftwaschern, Verbesserung chemischer Reaktionen.



Baureihe 460



Baureihe 461



Kunststoffausführung

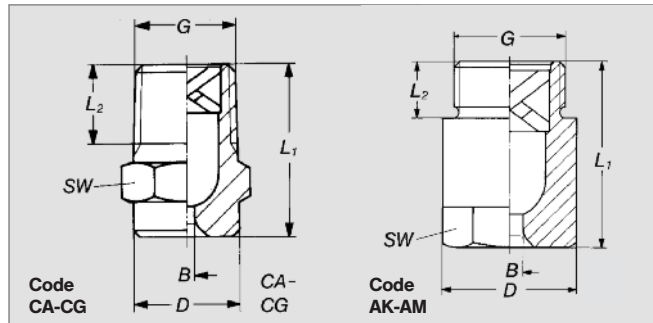

Code	G	Abmessungen [mm]			SW	Gewicht Ms
		L ₁	L ₂	D		
CA	EN 10226 R 1/8	18,0	6,5	10,0	11	15 g
CC	EN 10226 R 1/4	22,0	10,0	13,0	14	17 g
CE	EN 10226 R 3/8	24,5	10,0	16,0	17	30 g
CE	EN 10226 R 3/8	30,0	10,0	16,0	17	50 g
CG	EN 10226 R 1/2	32,5	13,0	21,0	22	67 g
CG	EN 10226 R 1/2	43,5	13,0	21,0	22	85 g
AK	G 3/4 ISO 228	42,0	15,0	32,0	27	170 g
AK	G 3/4 ISO 228	50,0	15,0	32,0	27	200 g
AM	G 1 A ISO 228	56,0	17,0	40,0	36	360 g

Technische Änderungen vorbehalten.

Bitte erfragen Sie bei kritischer Einbausituation die exakten Baumaße!

Strahlwinkel	Bestell-Nr.										B Ø [mm]	E Ø [mm]	ṽ [l/min]								Strahldurchmesser D bei p=2 bar	
	Type	Material-Nr.			Code								p [bar]									
		17	30	5E	EN 10226 R 1/8	EN 10226 R 1/4	EN 10226 R 3/8	EN 10226 R 1/2	G 3/4A ISO 228	G 1A ISO 228			0,5	1,0	2,0	3,0	5,0	7,0	10,0			
45°	460.403	○	○	-	CA	-	-	-	-	-	1,20	0,85	0,57	0,76	1,00	1,18	1,44	1,65	1,90	160	400	
	460.523	○	○	-	CA	-	-	-	-	-	1,50	1,35	1,15	1,52	2,00	2,35	2,89	3,30	3,81	160	400	
	460.603	○	○	-	-	CC	CE	-	-	-	1,90	1,80	1,81	2,39	3,15	3,70	4,54	5,20	6,00	160	400	
	460.643	○	○	-	-	CC	CE	-	-	-	2,15	2,00	2,30	3,03	4,00	4,70	5,77	6,60	7,61	160	400	
	460.683	-	○	-	-	CC	CE	-	-	-	2,40	2,00	2,87	3,79	5,00	5,88	7,21	8,25	9,52	160	400	
	460.703	-	○	-	-	-	CE	-	-	-	2,55	2,20	3,22	4,24	5,60	6,59	8,08	9,24	10,66	160	400	
	460.723	○	○	-	-	-	CE	CG	-	-	2,70	2,35	3,62	4,77	6,30	7,41	9,09	10,40	11,99	160	400	
	460.783	-	○	-	-	-	-	CG	-	-	3,20	3,20	5,17	6,82	9,00	10,58	12,98	14,85	17,12	160	400	
460.843	-	○	-	-	-	-	CG	-	-	3,80	3,70	7,18	9,47	12,50	14,70	18,03	20,63	23,80	160	400		
60°	460.404	○	○	-	CA	-	-	-	-	-	1,20	0,85	0,57	0,76	1,00	1,18	1,44	1,65	1,90	220	560	
	460.444	○	-	-	CA	-	-	-	-	-	1,30	1,05	0,72	0,95	1,25	1,47	1,80	2,06	2,38	220	560	
	460.484	○	○	-	CA	-	-	-	-	-	1,45	1,15	0,92	1,21	1,60	1,88	2,31	2,64	3,05	220	560	
	460.524	○	○	-	CA	-	-	-	-	-	1,60	1,20	1,15	1,52	2,00	2,35	2,89	3,30	3,81	220	560	
	460.604	○	○	-	CA	-	CE	-	-	-	2,05	1,40	1,81	2,39	3,15	3,70	4,54	5,20	6,00	220	560	
	460.644	○	○	○	-	CC	CE*	-	-	-	2,40	1,90	2,30	3,03	4,00	4,70	5,77	6,60	7,61	220	560	
	460.684	○	○	-	-	CC	CE	-	-	-	2,60	2,00	2,87	3,79	5,00	5,88	7,21	8,25	9,52	220	560	
	460.724	○	○	-	-	CC	CE	-	-	-	2,90	2,00	3,62	4,77	6,30	7,41	9,09	10,40	11,99	220	560	
	460.764	○	○	-	-	-	CE	-	-	-	3,25	2,85	4,59	6,06	8,00	9,41	11,54	13,20	15,22	220	560	
	460.804	○	○	-	-	-	CE	-	-	-	3,60	2,95	5,74	7,58	10,00	11,76	14,43	16,51	19,04	220	560	
	460.844	○	○	-	-	-	-	CG	-	-	4,00	3,30	7,18	9,47	12,50	14,70	18,03	20,63	23,80	220	560	
	460.884	○	○	-	-	-	-	CG	-	-	4,50	3,70	9,19	12,13	16,00	18,82	23,08	26,41	30,46	220	560	
	460.924	○	○	-	-	-	-	-	AK	-	5,20	4,50	11,49	15,16	20,00	23,52	28,85	33,01	38,07	220	560	
	460.964	○	○	○	-	-	-	-	AK	-	5,80	4,90	14,36	18,95	25,00	29,40	36,07	41,26	47,59	220	560	
	461.044	○	○	-	-	-	-	-	-	AM	7,20	5,40	22,97	30,31	40,00	47,04	57,71	66,02	76,15	220	560	
	461.084	○	○	-	-	-	-	-	-	AM	8,60	6,50	28,72	37,89	50,00	58,80	72,14	82,53	95,18	220	560	

B = Bohrungs-Ø · E = Engster Querschnitt

*Nur in Material 30

Fortsetzung der Tabelle auf der folgenden Seite.

Umrechnungsformel für diese Baureihe:
(≤ 10 bar)

$$\dot{V}_2 = \dot{V}_1 * \left(\frac{p_2}{p_1} \right)^{0,4}$$





Axial-Vollkegeldüsen

Baureihe 460 / 461



Strahlwinkel	Bestell-Nr.										B Ø [mm]	E Ø [mm]	V̇ [l/min]								Strahldurchmesser D bei p=2 bar	
	Type	Material-Nr.			Code								p [bar]									
		17	30	5E	EN 10226 R 1/8	EN 10226 R 1/4	EN 10226 R 3/8	EN 10226 R 1/2	G 3/4 A ISO 228	G 1 A ISO 228			0,5	1,0	2,0	3,0	5,0	7,0	10,0	H = 200 mm	H = 500 mm	
	1.4571	Ms	PVDF																			
90°	460.326	-	-	○	CA	-	-	-	-	-	0,80	0,55	0,23	0,30	0,40	0,47	0,58	0,66	0,76	380	860	
	460.406	○	○	○	CA	-	-	-	-	-	1,20	0,85	0,57	0,76	1,00	1,18	1,44	1,65	1,90	380	860	
	460.446	-	-	-	CA	-	-	-	-	-	1,30	1,00	0,72	0,95	1,25	1,47	1,80	2,06	2,38	380	860	
	460.486	○	○	○	CA	-	-	-	-	-	1,45	1,20	0,92	1,21	1,60	1,88	2,31	2,64	3,05	380	860	
	460.526	○	○	○	CA	-	-	-	-	-	1,65	1,30	1,15	1,52	2,00	2,35	2,89	3,30	3,81	380	860	
	460.566	○	○	-	CA	-	-	-	-	-	1,85	1,30	1,44	1,89	2,50	2,94	3,61	4,13	4,76	380	860	
	460.606	○	○	○	CA	-	CE	-	-	-	2,05	1,45	1,81	2,39	3,15	3,70	4,54	5,20	6,00	380	860	
	460.646	○	○	○	-	CC	CE	-	-	-	2,30	1,80	2,30	3,03	4,00	4,70	5,77	6,60	7,61	390	960	
	460.686	○	○	-	-	CC	CE	-	-	-	2,60	1,80	2,87	3,79	5,00	5,88	7,21	8,25	9,52	390	960	
	460.726	○	○	○*	-	CC	CE	-	-	-	2,95	2,00	3,62	4,77	6,30	7,41	9,09	10,40	11,99	390	960	
	460.746	-	-	○	-	-	CE	-	-	-	3,30	1,90	4,08	5,38	7,10	8,35	10,24	11,72	13,52	390	960	
	460.766	○	○	○	-	-	CE	-	-	-	3,30	2,40	4,59	6,06	8,00	9,41	11,54	13,20	15,22	390	960	
	460.806	○	○	○	-	-	CE	-	-	-	3,70	2,70	5,74	7,58	10,00	11,76	14,43	16,51	19,04	390	960	
	460.846	○	○	○	-	-	CE	-	-	-	4,05	3,20	7,18	9,47	12,50	14,70	18,03	20,63	23,80	390	960	
	460.886	○	○	○	-	-	-	CG	-	-	4,70	3,10	9,19	12,13	16,00	18,82	23,08	26,41	30,46	390	960	
	460.926	○	○	-	-	-	-	CG	-	-	5,20	3,80	11,49	15,16	20,00	23,52	28,85	33,01	38,07	390	960	
	460.966	○	○	○	-	-	-	CG	AK	-	5,80	3,80	14,36	18,95	25,00	29,40	36,07	41,26	47,59	390	960	
	461.006	○	-	-	-	-	-	CG	AK	-	6,40	3,80	18,09	23,87	31,50	37,05	45,45	51,99	59,97	390	960	
461.046	○	○	⊗	-	-	-	-	AK	-	7,20	5,30	22,97	30,31	40,00	47,04	57,71	66,02	76,15	390	960		
461.086	○***	-	-	-	-	-	-	AK	AM	8,20	5,30	28,72	37,89	50,00	58,80	72,14	82,53	95,18	390	960		
461.126	○	○	-	-	-	-	-	-	AM	9,30	6,50	36,18	47,75	63,00	74,09	90,89	103,98	119,93	390	960		
461.146	○	-	○	-	-	-	-	-	AM	9,90	6,70	40,78	53,81	71,00	83,50	102,43	117,19	135,16	390	960		
120°	460.368	○	○	-	CA	-	-	-	-	0,95	0,70	0,36	0,48	0,63	0,74	0,91	1,04	1,20	680	1220		
	460.408	○	○	○	CA	-	-	-	-	1,20	0,85	0,57	0,76	1,00	1,18	1,44	1,65	1,90	680	1220		
	460.448	○	○	-	CA	-	-	-	-	1,30	0,90	0,72	0,95	1,25	1,47	1,80	2,06	2,38	680	1220		
	460.488	○	○	○	CA	-	-	-	-	1,50	1,00	0,92	1,21	1,60	1,88	2,31	2,64	3,05	680	1220		
	460.528	○	○	○	CA	-	-	-	-	1,65	1,20	1,15	1,52	2,00	2,35	2,89	3,30	3,81	680	1220		
	460.568	○	○	-	CA	-	-	-	-	1,90	1,35	1,44	1,89	2,50	2,94	3,61	4,13	4,76	680	1220		
	460.608	○	○	○	CA	-	-	-	-	2,10	1,40	1,81	2,39	3,15	3,70	4,54	5,20	6,00	680	1220		
	460.648	○	○	○	-	CC	CE	-	-	-	2,45	1,60	2,30	3,03	4,00	4,70	5,77	6,60	7,61	680	1330	
	460.688	○	○	-	-	CC	CE	-	-	-	2,75	1,80	2,87	3,79	5,00	5,88	7,21	8,25	9,52	680	1330	
	460.728	○	○	○*	-	CC	CE	-	-	-	3,10	1,90	3,62	4,77	6,30	7,41	9,09	10,40	11,99	680	1330	
	460.748	-	-	○	-	-	CE	-	-	-	3,30	1,90	4,08	5,38	7,10	8,35	10,24	11,72	13,52	680	1330	
	460.768	○	○	○	-	-	CE	-	-	-	3,50	1,90	4,59	6,44	8,00	9,41	11,54	13,20	15,22	680	1330	
	460.808	○	○	○	-	-	CE	-	-	-	3,80	2,40	5,74	7,58	10,00	11,76	14,43	16,51	19,04	680	1330	
	460.848	○	○	○	-	-	CE	-	-	-	4,20	2,70	7,18	9,47	12,50	14,70	18,03	20,63	23,80	680	1330	
	460.888	○**	○	○	-	-	CE	CG	-	-	4,60	3,10	9,19	12,13	16,00	18,82	23,08	26,41	30,46	680	1330	
	460.928	○	○	-	-	-	-	CG	-	-	5,30	3,30	11,49	15,16	20,00	23,52	28,85	33,01	38,07	680	1330	
	460.968	○	○	○**	-	-	-	CG	AK	-	5,90	4,10	14,36	18,95	25,00	29,40	36,07	41,26	47,59	680	1330	
	461.048	○	○	⊗	-	-	-	-	AK	-	7,60	4,90	22,97	30,31	40,00	47,04	57,71	66,02	76,15	680	1330	
461.128	○	○	-	-	-	-	-	-	AM	9,60	6,60	36,18	47,75	63,00	74,09	90,89	103,98	119,93	680	1330		
461.148	○	-	-	-	-	-	-	-	AM	10,00	6,60	40,78	53,81	71,00	83,50	102,43	117,19	135,16	680	1330		

- B = Bohrungs-ø · E = Engster Querschnitt
 ⊗ Werkstoff PP (Material-Nr. 53), Anschluß EN 10226 R 3/4 (Code CK)
 * Nur mit Code CE erhältlich
 ** Nur mit Code CG erhältlich
 *** Nur mit Code AM erhältlich

Die Ausklappseite am Katalogende bietet Ihnen eine Übersicht über die verschiedenen Montagemöglichkeiten. Umfangreiches Montagezubehör finden Sie unter der Rubrik „Zubehör“.

Bestellbeispiel: Type + Material-Nr. + Code = Bestellnummer
 460.406 + 17 + CA = 460.406.17.CA



$$\dot{V}_2 = \dot{V}_1 \cdot \left(\frac{P_2}{P_1} \right)^{0,4}$$